

**ALTERNATE VAULT BOTTOM**

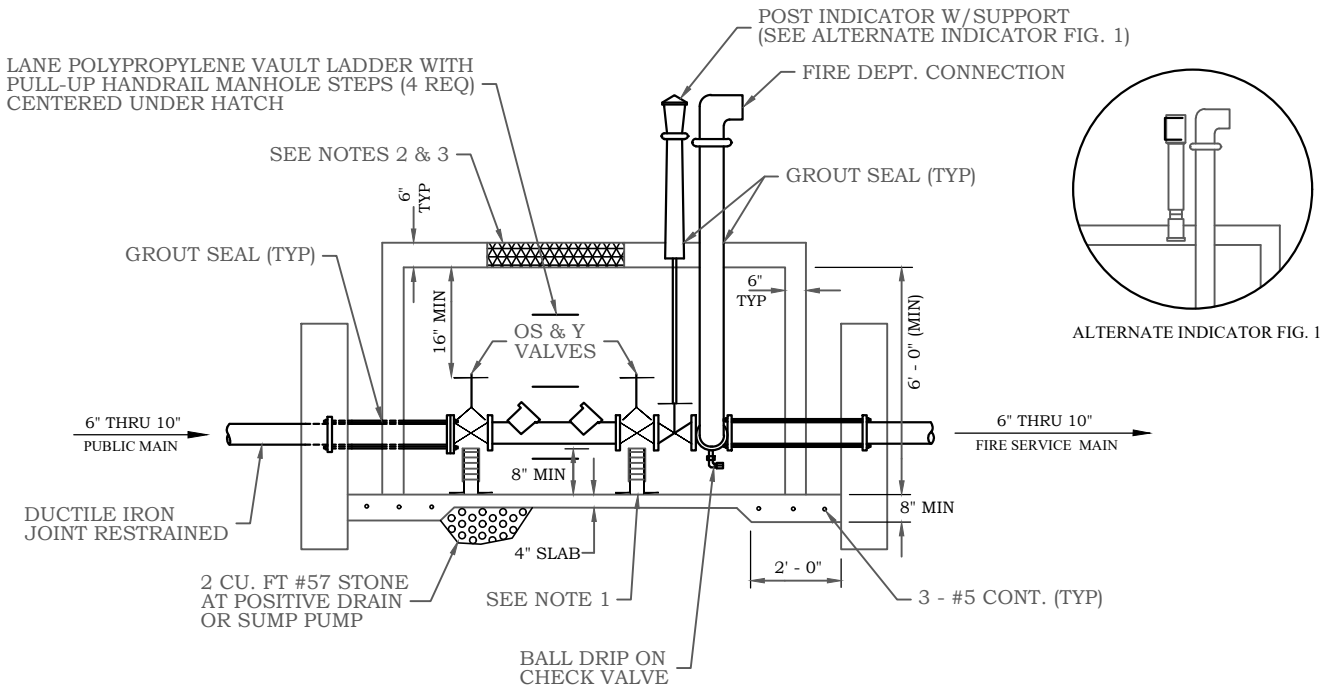

**PROFILE VIEW**

**NOTES:**

1. PIPE SADDLE SUPPORT (B-LINE B3095 & B3098 OR EQUAL, 2EA MIN). CONCRETE CAP BLOCK OR POURED CONCRETE FOOTING BEARING ON COMPACTED CRUSHED STONE UNDER PIPE STAND (TYP). 12" CONCRETE SUPPORTS (3,000 PSI, HEIGHT TO BE DETERMINED IN FIELD, TYP 4 PLACES).
2. 36"x36" ALUMINUM HATCH COVER (BILCO MODEL J-4 ALUMINUM OR APPROVED EQUAL) CAST INTO TOP SLAB CENTERED OVER DEVICE.
3. DESIGN SHOWN IS FOR NON-TRAFFIC AREAS ONLY. IF NEEDED IN TRAFFIC AREA ADEQUATE STRUCTURAL DESIGN MUST BE PROVIDED.
4. SUBGRADE UNDER STRUCTURE AND BACKFILL AROUND STRUCTURE AND THRUST COLLARS SHALL BE COMPACTED TO 95% MAX DRY DENSITY.
5. POST INDICATOR VALVE MAY BE ELIMINATED IF SUPPLIER PROVIDES AN ACCEPTABLE METHOD FOR ATTACHING THE POST INDICATOR ASSEMBLY TO DOWNSTREAM GATE VALVE.
6. PIV AND FDC SHOULD BE A MINIMUM OF 36" AND A MAXIMUM OF 48" ABOVE TOP OF GRADE.

NO REVISION OR MODIFICATION OF THIS DETAIL SHALL BE MADE WITHOUT PRIOR WRITTEN APPROVAL FROM AUGUSTA UTILITIES DEPARTMENT.

**APPROVED JAN. 2020**

REVISED: JANUARY 2018

**FIRE VAULT (ALT. 1)**

**AUGUSTA UTILITIES DEPARTMENT  
452 WALKER STREET, SUITE 200  
AUGUSTA, GA 30901**

**AUD DETAIL 1.21.2**

